

Dimensions of MSA-S / MSA-LS

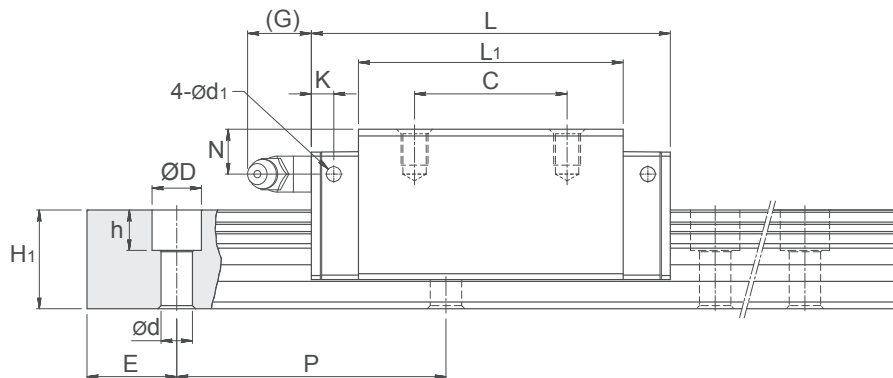

Unit: mm

Model No.	External dimension					Carriage dimension										Grease Nipple
	Height H	Width W	Length L	W ₂	H ₂	B	C	S x l	L ₁	T	N	G	K	d ₁		
MSA 15 S	28	34	56.3	9.5	4.2	26	26	M4×5	39.3	7.2	8.3	7	3.2	3.3	G-M4	
MSA 20 S	30	44	72.9	12	5	32	36	M5×6	51.3	8	5	12	5.8	3.3	G-M6	
MSA 20 LS			88.8						67.2							
MSA 25 S	40	48	81.6	12.5	6.5	35	35	M6×8	59	10	10	12	5.8	3.3	G-M6	
MSA 25 LS			100.6						78							
MSA 30 S	45	60	97	16	8	40	40	M8×10	71.4	11.7	10	12	6.8	3.3	G-M6	
MSA 30 LS			119.2						93.6							
MSA 35 S	55	70	111.2	18	9.5	50	50	M8×12	81	12.7	15	11.5	8.6	3.3	G-M6	
MSA 35 LS			136.6						106.4							
MSA 45 S	70	86	137.7	20.5	10	60	60	M10×17	102.5	16	20	13.5	10.6	3.3	G-PT 1/8	
MSA 45 LS			169.5						80							
MSA 55 S	80	100	162.1	23.5	13	75	75	M12×18	119.5	18	21	13.5	8.9	3.3	G-PT 1/8	
MSA 55 LS			200.1						95							
MSA 65 S	90	126	199	31.5	15	76	70	M16×20	149	23	19	13.5	8.9	3.3	G-PT 1/8	
MSA 65 LS			253						120							

Note: The basic dynamic load rating C of ball type is based on the 50 km for nominal life. The conversion between C for 50 km and C₁₀₀ for 100 km is C=1.26 x C₁₀₀.

Note*: Single: Single carriage/ Double: Double carriages closely contacting with each other.

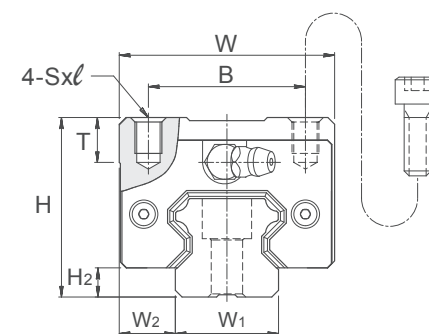
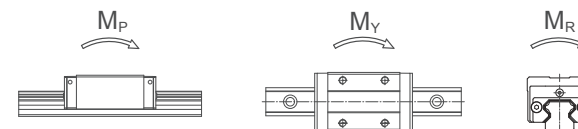

Unit: mm

Model No.	Rail dimension					Basic load rating		Static moment rating				Weight		
	Width W ₁	Height H ₁	Pitch P	E std.	D x h x d	Dynamic C kN	Static C ₀ kN	M _p kN-m		M _y kN-m		M _r kN-m	Carriage kg	Rail kg/m
								Single*	Double*	Single*	Double*			
MSA 15 S	15	15	60	20	7.5×5.3×4.5	11.8	18.9	0.12	0.68	0.12	0.68	0.14	0.18	1.5
MSA 20 S	20	18	60	20	9.5×8.5×6	19.2	29.5	0.23	1.42	0.23	1.42	0.29	0.3	2.4
MSA 20 LS						23.3	39.3	0.39	2.23	0.39	2.23	0.38	0.39	
MSA 25 S	23	22	60	20	11×9×7	28.1	42.4	0.39	2.20	0.39	2.20	0.48	0.52	3.4
MSA 25 LS						34.4	56.6	0.67	3.52	0.67	3.52	0.63	0.63	
MSA 30 S	28	26	80	20	14×12×9	39.2	57.8	0.62	3.67	0.62	3.67	0.79	0.86	4.8
MSA 30 LS						47.9	77.0	1.07	5.81	1.07	5.81	1.05	1.12	
MSA 35 S	34	29	80	20	14×12×9	52.0	75.5	0.93	5.47	0.93	5.47	1.25	1.45	6.6
MSA 35 LS						63.6	100.6	1.60	8.67	1.60	8.67	1.67	1.9	
MSA 45 S	45	38	105	22.5	20×17×14	83.8	117.9	1.81	10.67	1.81	10.67	2.57	2.83	11.5
MSA 45 LS						102.4	157.3	3.13	16.95	3.13	16.95	3.43	3.7	
MSA 55 S	53	44	120	30	23×20×16	123.6	169.8	3.13	17.57	3.13	17.57	4.50	4.12	15.5
MSA 55 LS						151.1	226.4	5.40	28.11	5.40	28.11	6.00	4.91	
MSA 65 S	63	53	150	35	26×22×18	198.8	265.3	6.11	33.71	6.11	33.71	8.36	6.43	21.9
MSA 65 LS						253.5	375.9	11.84	57.32	11.84	57.32	11.84	8.76	